

LIÊN HỆ : 0979 349 375 CÔNG TY LÂM TUỆ ĐỨC

**TECHNICAL MANUAL
FOR
MODEL BA-200
OIL IN WATER ALARM**

PART NUMBER: 01-5421-00027

NSN: 6680-01-235-1599

MANUFACTURED BY:

**INVENTIVE SYSTEMS INCORPORATED
P.O. BOX 220
21797-C NORTH CORAL DRIVE
LEXINGTON PARK, MARYLAND 20650
U.S.A.**

Phone: (301) 863-5153

Fax: (301) 863-7583

Web: www.oilinwater.org

E-mail: isi@oilinwater.org

FSCM: 9S280

01 September 1993

MODEL BA-200

OPTIONS CONFIGURATION

Inventive Systems Incorporated Model BA-200 Oil in Water Content Alarm has numerous model types and options that are customer specified. These model types and options are delineated below and those marked have been installed in your unit.

- ___ High Temperature Sensor Head (model type BA-200/HT)
- ___ Explosion Proof Unit (model type BA-200/X)
- ___ Weatherproof Unit (model type BA-200/WP)
- ___ 4 to 20 mA Output
- ___ Navy, 6 hole 150# (10 bar) Flange
- ___ ANSI B16.5 150# (10 bar) Flange
- ___ DIN 2576 150# (10 bar) Flange
- ___ PPM Calibrated Set Point
- ___ 220-240VAC 50/60Hz Input Power
- ___ LCD meter

** RECORD UNIT'S SERIAL NUMBER HERE _____ (to be completed by user)

SAFETY SUMMARY

The following are general safety precautions not related to any specific procedures and which therefore do not appear elsewhere in this publication.

KEEP AWAY FROM POTENTIALLY LIVE CIRCUITS

This equipment derives its power from the 115V 60 Hz AC supply and its signal inputs and outputs are connected to similarly powered equipments. Malfunctions in this and attached equipments, including test equipments, may place 115V AC on signal circuits. Do not assume the safety of low-voltage DC circuits. Do not assume, but check chassis-to-ground circuit integrity when the chassis is on the workbench.

DO NOT SERVICE OR ADJUST ALONE

Under no circumstances should any person reach into the chassis for the purpose of servicing or adjusting the equipment except in the presence of someone capable of rendering aid.

RESUSCITATION

Personnel working on this equipment should be familiar with modern methods of resuscitation.

TABLE OF CONTENTS

	Page	
1.0 INTRODUCTION		1
1.1 Purpose		1
1.2 Description		1
1.3 Specifications		1
2.0 INSTALLATION		4
2.1 Mechanical	4	4
2.2 Electrical		4
3.0 GENERAL THEORY OF OPERATION	5	5
3.1 Principles of Operation		
4.0 OPERATING INSTRUCTIONS	6	7
5.0 MAINTENANCE		7
5.1 Preventive Maintenance		7
5.2 Fault Isolation & Trouble Shooting		11
6.0 STORAGE INSTRUCTIONS	15	15
6.1 Preparation for Shipment		
7.0 FIGURES		21

LIST OF FIGURES

Figure 1 BA-200 Center of Gravity	Page 22
Figure 2 BA-200 Installation	Page 23
Figure 3 BA-200 External Wiring	Page 24
Figure 4 BA-200 Cross Section of Sensor Head	Page 25
Figure 5 BA-200 Sensor Board	Page 26
Figure 6 BA-200 Sensor Board Schematic	Page 27
Figure 7 BA-200 Power Wiring	Page 29
Figure 8 BA-200 Sensor Head IPB	Page 30
Figure 9 BA-200 Frame IPB	Page 31
Figure 10 BA-200 Power Supply Card	Page 32
Figure 11 BA-200 Installation	Page 33

Appendix A CL001 4-20mA Option

REVISION LIST

Date Affected Pages

01 SEP 93 Original
07 SEP 95 iv,v,4,6,9,24,26,29,33
22 OCT 96 i,v,2,3,4,5,14,22,23
06 DEC 96 iii,iv,v,Appendix A
07 JUL 98 Crash recovery

1.0 INTRODUCTION

1.1 PURPOSE

This manual describes the installation, operation, maintenance and calibration of the Inventive Systems' model BA-200 OILARM oil in water content alarm.

1.2 DESCRIPTION

The BA-200 OILARM is an instrument that detects and measures the amount of oil in water and compares the results with a threshold value. This threshold value can be adjusted to any level between 2 and 500 parts per million (PPM) and at such values required by local and international regulations. Samples are taken at a frequency which complies with marine sampling standards. An alarm relay output is provided, and activated when the measured oil concentration is higher than the preset value. The alarm relay output contacts can be used to switch ON or OFF a user supplied auxiliary contactor for control of valves, pumps, and/or an external alarm event-action circuit. A local visual and audio alarm is provided as well as a voltage output and a power fail relay output. In addition, many options can be provided such as extended temperature range, explosion proofing strip charts, meters and 4-20ma outputs.

1.3 SPECIFICATIONS

MANUFACTURER:

Inventive Systems Incorporated
P.O. Box 220
21797-C North Coral Drive
Lexington Park, Maryland
U.S.A.
PHONE: (301) 863-5153
FAX: (301) 863-7583

CERTIFICATIONS:

U.S. Coast Guard: 162.050/3013/1
International Maritime Organization: MEPC.60(33)
American Bureau of Shipping: 95-NN7502-X

CALIBRATION SET POINT:

15 Parts Per Million (PPM) or user specified
(refer to page i for the setting of your unit)

CALIBRATION ADJUSTMENT:

2 to 100 PPM (2 TO 500 ppm WITH SPECIAL FACTORY SETUP)

SAMPLE PERIOD:

8.6 Seconds

ACCURACY:

+/- 2 PPM @ 15 PPM
+/- 10 PPM @ 100 PPM

REPEATABILITY:

+/- 2 PPM @ 15 PPM

POWER SOURCE:

115VAC +/- 10% (220-240vac 50/60hZ optional)
60 Hz
1 AMP
SINGLE PHASE

FLOW RATE:

0 to >>50 GAL/MIN (11.4 m3/h)

WEIGHT:

15.1 POUNDS (6.7 kg)

MOUNTING:

150# (10 bar) Navy 6 hole flange (standard)
or ANSI B16.5 150# (10 bar) Flat Face Flange
or DIN 2576 150# (10 bar) Flat Faced Flange

ALARM:

Internal Audio Buzzer
Internal Red LED Indicator

ALARM DELAY:

Set at 12 Seconds
Adjustable from 10 to 30 Seconds

ALARM OUTPUT:

SPDT
10 amps @ 120VAC or 1/4 HP (.19 kW)
Voltage Free

OTHER OUTPUTS

SPST Power Fail (N/C)
10 amp @ 120VAC or 1/4 HP (.19kW)
Voltage free

ENVIRONMENTAL:

STORAGE TEMPERATURE LIMITS DEG. F:

MAX: 158o F (70oC) MIN: -40oF (-40oC)

OPERATING TEMPERATURE LIMITS DEG. F:

MAX: 158o F (70oC) MIN: 28oF (0oC) (SAMPLE) 0o(AMBIENT)

MAXIMUM SAMPLE TEMPERATURE DEG. F:

MAX: 240o F (116oC)(High Temperature (HT) Model)
MAX: 158o F (70oC) (all other models)

RELATIVE HUMIDITY AT STORAGE TEMP. %:

MAX: 90 MIN: 0

RELATIVE HUMIDITY AT OPERATING TEMP. %:

MAX: 90 MIN: 0

SHIP MOTION:

ROLL: NO RESTRICTION
PITCH: NO RESTRICTION
PERMANENT TRIM: NO RESTRICTION
PERMANENT LIST: NO RESTRICTION

PRESSURE:

100 LBS (7 bar) STATIC FOR 5 MINUTES
50 LBS (3.5 bar) OPERATING PRESSURE MAXIMUM

SPECIAL TOOLS & TEST FIXTURES:

NONE provided
NONE required

WEIGHT:

DRY WEIGHT:

15.1 POUNDS (6.7 kg)

WET WEIGHT:

15.1 POUNDS (6.7 kg)

SHIPPING WEIGHT:

17 POUNDS (7.7 kg)

CENTER OF GRAVITY:

REFER TO FIGURE 1

1.4 ITEMS FURNISHED

The BA-200 is furnished with the following items:

- BA-200 OILARM unit
- Technical Manual
- Calibration Certificate
- Coast Guard Certificate
- Warranty.

2.0 INSTALLATION

2.1 MECHANICAL

The BA-200 is installed to a water line by a 2 inch internal diameter tee that is welded or threaded into the line. Although the BA-200 may be mounted in any orientation, it is suggested that it be mounted horizontally with the name plate on top. On the tee is welded a 150-pound (10 bar) Navy, ANSI or DIN flange. The flange is located on the tee so that when the probe body of the BA-200 is inserted, it will protrude 1/4 to 1/2 inch into the inside diameter of the water line. (Refer to Figure 2 and Figure 11). In the design process, insure that the BA-200 will never sample air and be far enough down the line so that any air bubbles generated by a pump have time to dissipate. This may mean in gravity systems the installation of the unit be at a low point in the pipe run or installed in a "trap" arrangement. Sediment build up will shorten the life of the seals. Insure that the Sensor opening is clear of any protective covering such as tape. The flanges are then appropriately bolted together. This completes the mechanical installation.

2.2 ELECTRICAL

***** WARNING *****

INSURE POWER IS REMOVED FROM ALL WIRING BEFORE ELECTRICAL INSTALLATION IS ATTEMPTED

***** CAUTION *****

THIS UNIT CONTAINS STATIC (ESD) SENSITIVE PARTS. OBSERVE PROPER GROUNDING TECHNIQUES FOR HANDLING OF EQUIPMENT.

The user of the BA-200 must provide a 3/4 inch NPT strain relief that will accommodate their cabling requirements. The strain relief is inserted into the 3/4" NPT threaded hole in the base plate of the BA-200. Next refer to Figure 3. With the cover removed, insert the power and external alarm cables through the strain relief located in the base plate. Route the cables underneath the chassis, around to motor and locate the connector screw terminal blocks at the rear of the BA-200. Whether using 120 VAC 3 wire or 230 VAC 3 wire, connect the ground (safety, earth) to the ground (#4) screw terminal. If using 120 VAC 50/60 Hz, connect the hot (black) wire to the #6 screw terminal and the neutral (white) wire to the #5 terminal. If using 230 VAC, 50/60 Hz connect the +120 VAC (as measured to ground-safety, earth-) to the #6 screw terminal. Connect the -120 VAC (as measured to ground-safety, earth-) to the #5 screw terminal. Tighten all screws. Cabling to the external alarms relay contacts should now be made according to user requirements to screw terminals NC, NO, and COM (screw terminal 1,2 and 3 respectively). Tighten all screws as required and finally the cable strain relief. The cover should then be carefully replaced and power applied to the unit. This completes the installation of the BA-200.

Note: The BA-200 has been calibrate at the factory to you specifications. There is no need to re-calibrate the unit during pre or post installation. Attempts to re-calibrate the unit may lead to voiding of the warranty.

3.0 GENERAL THEORY OF OPERATION

The BA-200 measures the concentration of oil in water. It is housed in a metal box 8 x 6.5 x 4 inches (200 x 165 x 100 mm) and attached to a probe body and flange. A mechanical assembly driven by a 7 RPM motor moves samples into and out of a sample chamber. The sample chamber is located in the probe body and contains a light source, sensor cells and a temperature compensating device. An electronic printed wiring board and power supply board perform the electro-optic calculation of the concentration of oil in water. These are the basic elements that measure the concentration of oil in water.

3.1 PRINCIPLES OF OPERATION

Within the sensor probe, light is directed into a chamber filled with a sample. The light is measured by two photo devices, which transform light into electric current. Refer to Figure 4. One cell, the transmit photocell, is situated so that light from the sensor's lamp can reach it directly. The second cell, the scatter photocell, is in the shadow of a light-absorbing pin, the occluding rod. When the sample is clear, that is, when no oil is present, light from the lamp reaches the transmit cell unimpeded; no light reaches the scatter cell, which remains in the shadow cast by the occluding rod. When oil is present in the sample, the light is scattered by oil droplets and reaches the scatter cell. The angle between the transmit cell and the scatter cell favors the refraction angle for oil and tends to ignore the random scattering of particulate. As the concentration of oil in water increases, more light is scattered away from the transmit

cell

to scatter cell. The amount of oil in water is given by the ratio of scattered light to transmitted light. But since temperature differences affect photocell response, a temperature compensating Thermistor calibrates this ratio by correcting for discharge temperature changes. The sensor electronic board converts the electronic signals from the photocells to a voltage between 0 and 7 volts, which is proportional to the concentration of oil in water. To insure that the oil in water concentration measured by the probe is the same as the concentration in the discharge line, the probe piston draws in and ejects a sample from the sampling probe chamber seven times a minute. The piston, which is driven by a gearmotor turning at 7 RPM, automatically wipes clean the window that covers the sensor lamp and photocells.

4.0 OPERATING INSTRUCTIONS

The BA-200 has no operator controls and two indicators, one audio and one visual. If the set point for the oil in water concentration is exceeded, a pulsating buzzer is sounded and a red indicator light is lit. The red indicator light can be observed at the back of the unit, a few inches above the knurled nut that holds the cover in place. External alarms and indicators are the responsibility of the user.

To increase the life of the BA-200, the unit should not be run dry for extended periods of time. Another way to extend the life of the unit is to slave the BA-200 to the pump or whatever is driving the water through the line. Also refer precautions outlined in section 2.0, Installation.

There are no special power-up or power-down procedures or sequences.

5.0 MAINTENANCE

***** WARNING *****

SOME OF THE MAINTENANCE PROCEDURES IN THIS SECTION REQUIRE THE POWER TO BE APPLIED TO THE UNIT AND THE COVER REMOVED. PLEASE REVIEW THE SAFETY PRECAUTIONS OUTLINED AT THE BEGINNING OF THIS MANUAL.

***** CAUTION *****

THIS DEVICE CONTAINS STATIC SENSITIVE ELECTRONIC COMPONENTS. INSURE THAT PROPER ESD PROCEDURES ARE FOLLOWED.

This section deals with the preventive and corrective maintenance of the BA-200.

5.1 PREVENTIVE MAINTENANCE

The following paragraphs describe the periodic preventive maintenance checks and actions that should be performed on the BA-200. The Lithium Grease used in the following checks and procedures is "White Lithium Grease, 30-140, NLGI Grade 2".

5.1.1 MONTHLY CHECKS

At monthly intervals the mechanical portions and the water tight integrity of the BA-200 should be checked as follows:

- Remove power from the unit at the circuit breaker.
- Remove the knurled nut from the back of the unit and slide off the cover.
- Switch the power on.
- Check the sensor frame beneath the probe for droplets of water or water discoloration.
- Observe that the sensor plunger is reciprocating at 7 RPM or every 8.5 seconds.
- If any of the above conditions are not satisfactory, refer to the corrective maintenance portion of this manual.
- Turn off AC power.
- Replace cover.
- Return power to the unit as required.

5.1.2 QUARTERLY CHECKS

At 3 month intervals, the unit must be lubricated using a high quality lithium grease as outlined below:

- Remove AC power from the unit at the circuit breaker.
- Remove the knurled nut and cover.
- Use a wooden or non-metallic device to coat the drive wheel with grease. Do not get excess grease on other components of the unit.
- Replace the cover and knurled nut.
- Restore power to the unit as required.

5.1.3 BIENNIAL CALIBRATION

At six month intervals the BA-200 should be removed from the line and recalibrated. This service is available from the manufacturer at a nominal charge. The unit may be calibrated on site with a calibration kit available from the manufacturer. The model number of the calibration kit is OACK-3000 and contains the necessary equipment and oil to perform many calibrations.

If all the above procedures are followed in a timely manner, no cleaning will be required.

5.1.3.1 BA-200 CALIBRATION PROCEDURE

The following Calibration Procedure is to be used for all models of the BA-200 OILARM. Refer to Figure 5. Successful completion of this procedure validates the proper operation of the BA-200 OILARM.

TEST EQUIPMENT:

4 1/2 DIGIT Volt Ohm Meter (VOM)
OACK-3000 CALIBRATION KIT containing:
Probe Sleeve
Sleeve Cover
Oil Mix (sg 0.8866)
100 ml graduated cylinder
250 ml bottles (qty 2)
TEFLON disks
Microliter syringe

TEST SOLUTIONS:

100 PPM Oil in Water Solution
15 PPM Oil in Water Solution or appropriate Set Point
solution, e.g. 2 PPM, 50 PPM, etc.

TEST SETUP:

1. Set the BA-200 upright and place the black calibration sleeve over the top of the probe body.
2. Fill calibration sleeve with distilled water
3. Cover calibration sleeve with cover.
4. Allow unit to run for 5 minutes.
5. Place VOM ground lead on Test Point 10 (TP10).
6. Set VOM to Volts DC, 2 VDC Full Scale.
7. Replace water with fresh distilled water.

TEST PROCEDURE:

TEST
LEAD
STEP TO ADJUST for READING REMARKS

-
- 1 TP16 PR10 0.0186 +/- 0.0010
 - 2 VOM to 20 VDC Full Scale; Stop motor fully retracted
 - 3 TP1 PR1 0.000 +/- 0.002
 - 4 TP14 PR4 0.000 +/- 0.002
 - 5 TP2 PR2 0.000 +/- 0.020 VOLTAGE MAY DRIFT,
Start motor CENTER AROUND 0.000.
 - 6 JUMPER TP10 TO TP11
 - 7 TP3 PR3 0.000 +/- 0.002
 - 8 TP15 PR6 0.000 +/- 0.020
 - 9 REMOVE TP10 TO TP11 JUMPER
 - 10 REMOVE DISTILLED WATER FROM SLEEVE
 - 11 FILL SLEEVE WITH 100 PPM SOLUTION
 - 12 TP3 PR5 7.000 +/- 1.000 ANYWHERE 6.0 to 8.0

13 REMOVE 100 PPM SOLUTION

14 FLUSH 3 TIMES WITH DISTILLED WATER

15 FILL SLEEVE WITH SET POINT SOLUTION (15 PPM ETC.)

16 TP13 PR8 0.100 +/- 0.020

17 JUMPER TP11 TO TP10 FOR 30 SECONDS

18 REMOVE THE TP10 TO TP11 JUMPER AND RECORD THE TIME IT TAKES FOR THE ALARM TO ACTIVATE.

19 REPEAT STEPS 17 & 18 AND ADJUST PR7 FOR DELAY TIME DESIRED

20 REMOVE TP11 TO TP10 JUMPER

21 ADJUST PR8 SLOWLY UNTIL ALARM NO LONGER SOUNDS

22 IF OPTIONAL LCD METER IS INSTALLED ADJUST PR9 SUCH THAT METER READS 15.0 PPM +/- 0.2 PPM

23 CALIBRATION COMPLETE

5.2 FAULT ISOLATION & TROUBLE SHOOTING

The following is a list of symptoms and corrective actions to be taken to cure most problems and failures encountered in the maintenance of the BA-200 OILARM. When ordering parts from the factory please forward a copy of the configuration page and serial number of the unit being serviced.

The following is a list of the recommended spares for the BA-200 OILARM:

Part Number	Description
01-5421-50370	Reed Switch Assembly
01-5421-00031	Follower Assembly
01-5421-50380	Drive Wheel Assembly
01-5421-00015	Power Board
01-5421-00028	Sensor Head Assembly
01-5421-10009	Sensor Board
03-5421-30261	Motor
02-7000-00016	"O" Ring

Of the above items, only the Power Board and Sensor Board are on site serviceable items. The others are wear items and must be returned to the factory for refurbishment or replacement.

Refer to Figures 5 to 9 during the following paragraphs.

*******PLEASE OBSERVE WARNINGS AND CAUTIONS *******

TROUBLE SHOOTING STEPS

SYMPTOM CORRECTIVE ACTION

Motor fails to run.1. Check primary power.

2. Check quick disconnect connector.
3. Check for drive chain jam.
4. Replace motor.

Drive chain jammed.1. Check free movement of Sensor Head piston rod.

2. Check follower assembly.
3. Check drive wheel assembly.
4. Replace as required.

Sensor light not lit.1. Check 6VDC power supply.

2. Check light continuity, pins 1 & 6 (two gray wires) of sensor head connector.
3. Check PR10 operation.
4. Replace as required.

Erratic operation. 1. Check +/- 12VDC power supply card.

2. Replace if required.

Failure to alarm. 1. Check Sensor light (above).

2. Check all power supply voltages.
3. Perform Calibration (refer below).
4. Check Q1 operation on Sensor Board.
5. Check alarm relay operation on power supply card.
6. Replace as required.

The following steps relate to the individual steps in the calibration procedure (refer to section 5.1.3.1). The Sensor Board can be repaired on site by normal PCB repair techniques, however the Sensor Head MUST be returned to the factory with the Sensor Board for repair and calibration. WARNING: Each Sensor Board must be uniquely calibrated to the vagaries of an individual Sensor Head. Swapping Sensor Heads among different Sensor Boards and visa-versa will require that they be completely recalibrated as a pair.

Step 1 failure. 1. Check 6 VDC power module.

2. Check PR10.
3. Check bulb continuity.
4. Replace as required.

Step 2 failure. 1. N/A

Step 3 failure. 1. Insure oil free water.

2. Replace AR1.
3. Replace PR1.
4. Replace Sensor Head.

Step 4 failure. 1. Replace AR6.

2. Replace PR4.
3. Replace Sensor Head.

Step 5 failure. 1. Insure oil free water.

2. Replace AR2.
3. Replace PR2
4. Replace Sensor Head.

Step 6 failure. 1. N/A

Step 7 failure. 1. Replace AR3.

2. Replace PR3.
3. Replace C4.

Step 8 failure. 1. Replace AR7.

2. Replace PR6.

Step 9 failure. 1. N/A

Step 10 failure. 1. N/A

Step 11 failure. 1. N/A

Step 12 failure. 1. Check Reed Switch operation. Replace if required.

2. Replace C4.
3. Replace AR3.
4. Replace PR5.
5. Replace Sensor Board.
6. Replace Sensor Head.

Step 13 failure. 1. N/A

Step 14 failure. 1. N/A

Step 15 failure. 1. N/A

Step 16 failure. 1. Replace PR8.

2. Check +/- 12 VDC power.
3. Replace as required.

Step 17 failure. 1. N/A

Step 18 failure. 1. Replace AR4.

2. Replace AR5.
3. Replace PR7.
4. Replace Q1.
5. Replace alarm relay on power supply card. 6. Replace LED.
7. Replace Buzzer.

Step 19 failure. 1. Refer to Step 18.

Step 20 failure. 1. N/A

Step 21 failure. 1. Replace PR8.

2. Perform step 18 above.

Step 22 failure. 1. Replace AR7.

2. Replace PR9.

3. Replace optional LCD meter.

Step 23 failure. 1. Start over.

5.2.1 Disassembly

Please refer to Figure 8 and Figure 9. These figures are the Illustrated Parts Breakdown for the BA-200 OILARM. Standard mechanical tools are required for disassembly and no special tools are required. No attempt should be made to disassemble the Sensor Head. Sensor Head refurbishment can only be accomplished at the factory. Any attempt to disassemble the Sensor Head will result in complete destruction of the assembly and refurbishment will not be possible.

5.2.2 Repair

The reader is referred to the trouble shooting section of this manual for descriptions of repairable items.

5.2.3 Replacement.

The reader is again referred to the trouble shooting section of this manual for descriptions of the repairability of the various sub-assemblies and components of the BA-200 OILARM.

5.2.4 Reassembly

The reader is referred to Section 5.2.1 above. Simply reverse the order of disassembly.

5.2.5 Overhaul

The BA-200 OILARM can only be overhauled at the factory, with the exception of parts replacement as indicated in section 5.2 of this manual. Normal factory turn-around for a complete overhaul is 48 hours.

6.0 STORAGE INSTRUCTIONS

The environmental storage specifications listed in section one of this manual shall not be exceeded. If the temperature is expected to drop below 32 degrees Fahrenheit, any trapped water in the sensor head must be expunged. This may be accomplished by running the unit with the sensor head in a downward position and allowing gravity to draw out the majority of the water. The sensor head should then be covered to prevent dust and dirt from entering the sample chamber. This may be done with a section of plastic taped to the sensor probe flange. The entire unit should then be boxed and stored. The original shipping container and its inserts are ideal for storage. Care must be taken to ensure other material is not stacked on top and possibly crushing the case of the unit.

6.1 PREPARATION FOR SHIPMENT

The original shipping container and its inserts are the ideal way to package the unit for shipment. If the original container is no longer available, then normal packaging for delicate instruments should be employed. The unit shall then be marked "FRAGILE" and "DO NOT DROP". If the unit is being returned to the manufacturer, then they shall be contacted to obtain shipping addresses and to alert them of its arrival. A complete set of instructions shall be packed inside the container.

7.0 Illustrations

The following pages contain all the illustrations and drawings referenced in the previous sections of this manual.

LIÊN HỆ : 0979 349 375 CÔNG TY LÂM TUỆ ĐỨC

Pages 16 to 21

Left Intentionally Blank

LIÊN HỆ : 0979 349 375 CÔNG TY LÂM TUỆ ĐỨC

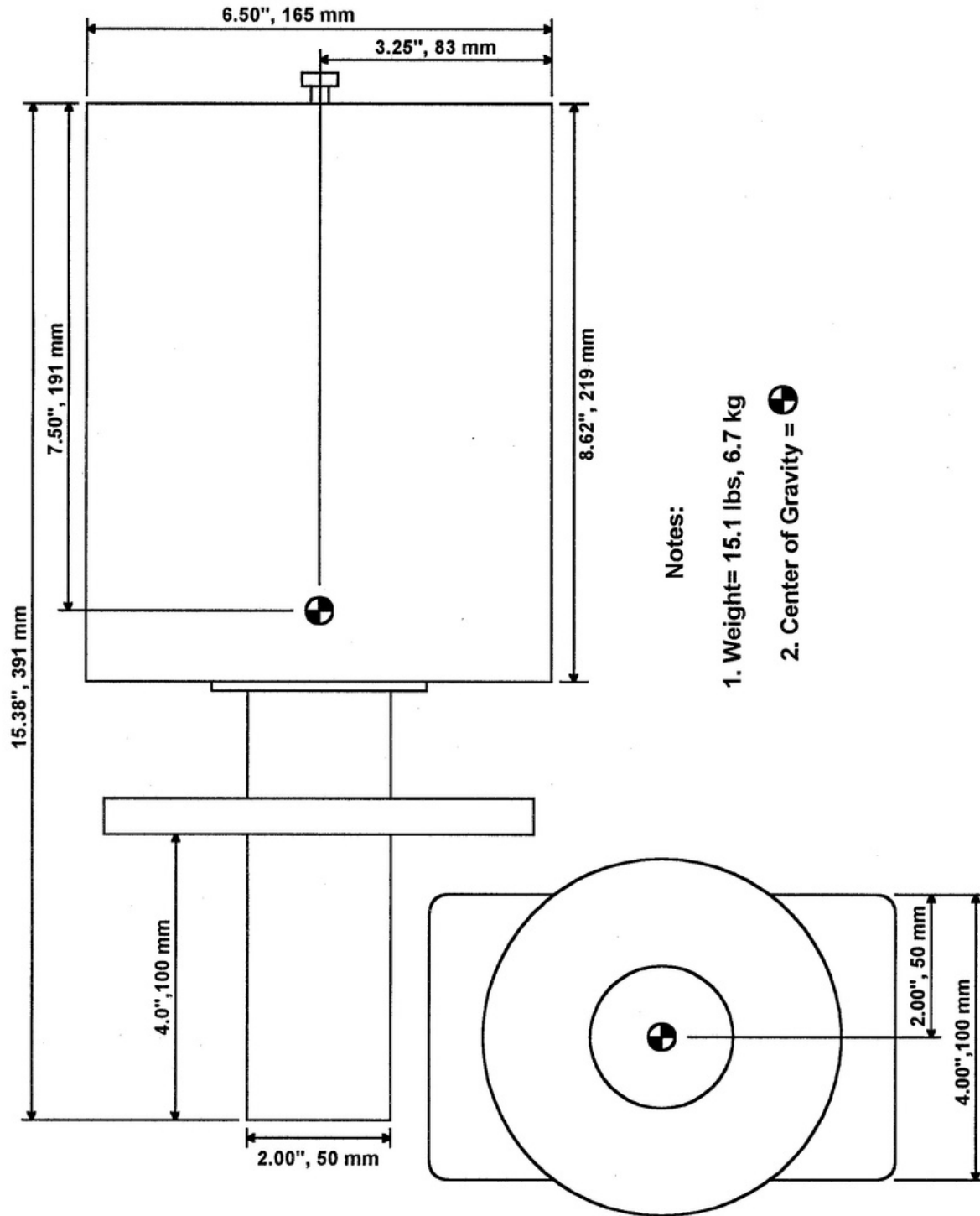
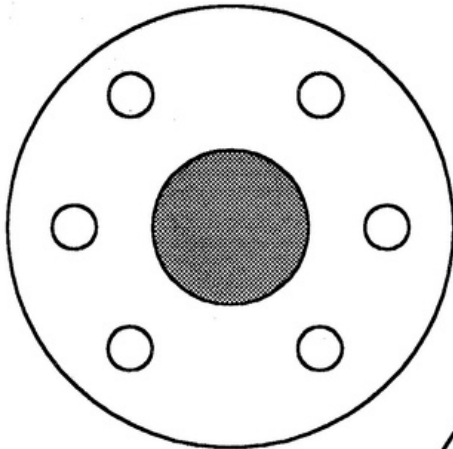

Figure 1 BA-200 Center of Gravity

LIÊN HỆ : 0979 349 375 CÔNG TY LÂM TUỆ ĐỨC

Flange Types and Hole Patterns



Navy (standard)
Hole Dia 0.562", 14.3 mm
Hole Circle 4.437", 122.7 mm
Dia 5.56", 141 mm

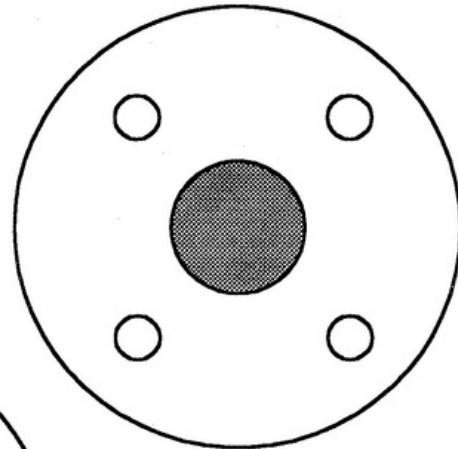

DIN 2576 (optional)
Hole Dia 0.709", 18 mm
Hole Circle 4.92", 125 mm
Dia 6.50", 165 mm

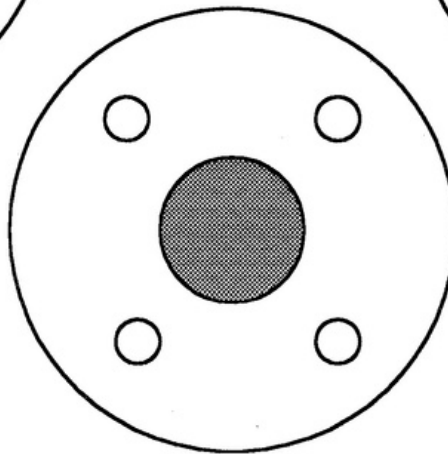

ANSI B16.5 (optional)
Hole Dia 0.630", 16 mm
Hole Circle 4.750", 120.7 mm
Dia 6.00", 152 mm

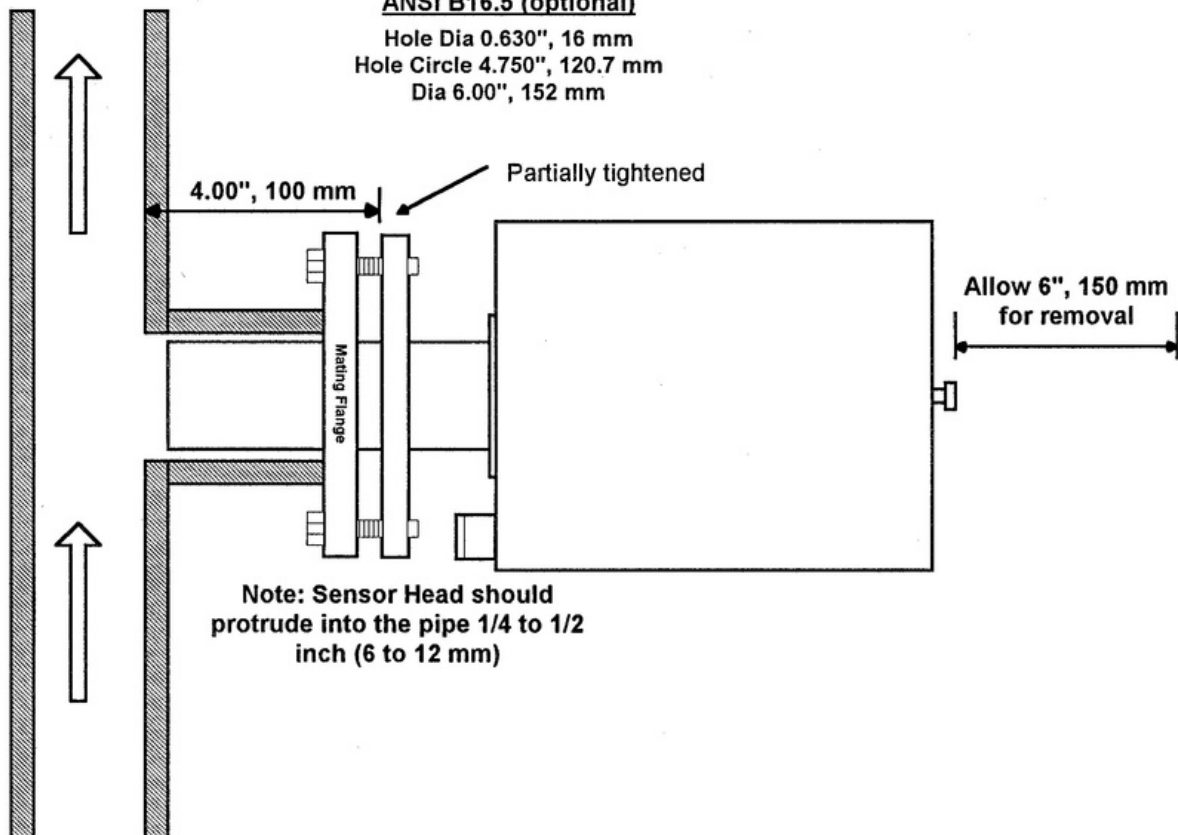
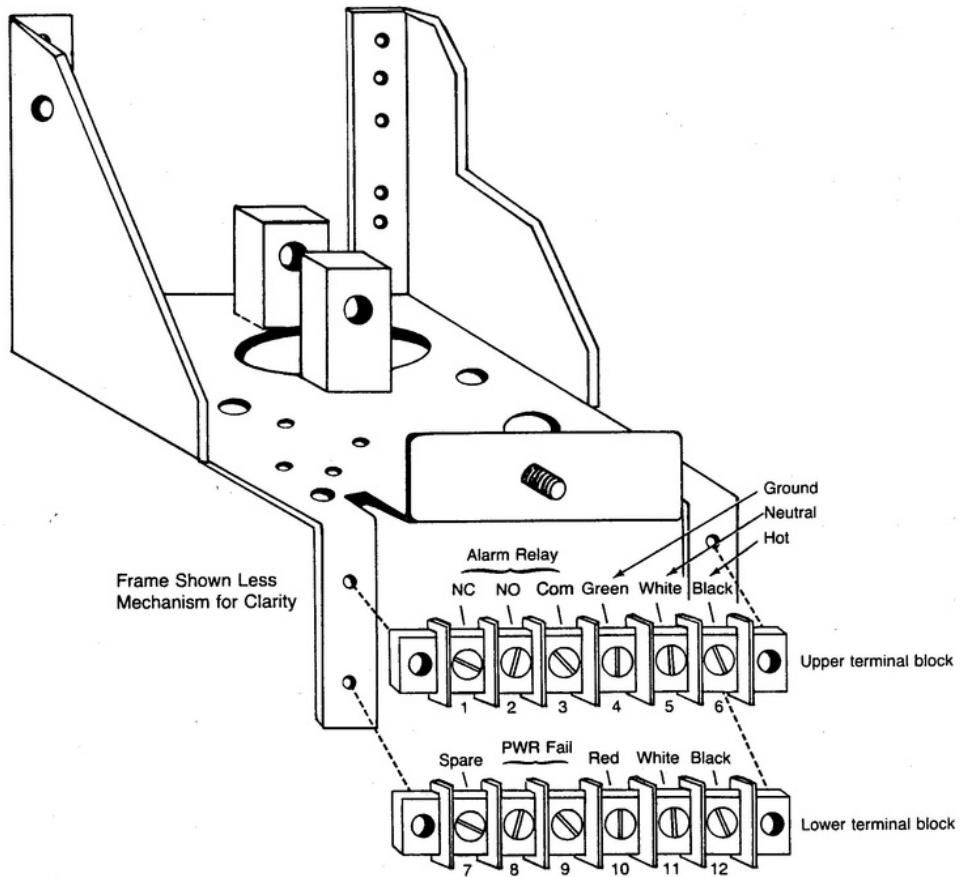

Figure 2 BA-200 Installation
23

LIÊN HỆ : 0979 349 375 CÔNG TY LÂM TUỆ ĐỨC



UPPER TERMINAL BLOCK

Alarm Relay

1. NC - Normally Closed - opens when excessive oil is detected
2. NO - Normally Open - closes when excessive oil is detected
3. Com - Common - common contact to terminal 1 and 2

Power Connections

- | | |
|-----------------------------------|-------------------|
| 4. Ground - (normally green) | or 230 VAC Ground |
| 5. Neutral - (normally white) | or -120 VAC |
| 6. 120 VAC Hot - (normally black) | or +120 VAC |

LOWER TERMINAL BLOCK

4-20mA (optional)

7. Out - 4-20mA signal output (otherwise Spare)
12. Return - 4-20mA signal return

Power Fail Relay

- 8 & 9 NC - Normally Closed - closes when AC power is applied to Oilarm®

Meter (optional)

10. +12VDC - meter supply voltage
11. Signal, 0 to 2 VDC meter signal, usually 0 to 200 ppm
12. Ground - meter ground

Figure 3 BA-200 External Wiring

LIÊN HỆ : 0979 349 375 CÔNG TY LÂM TUỆ ĐỨC

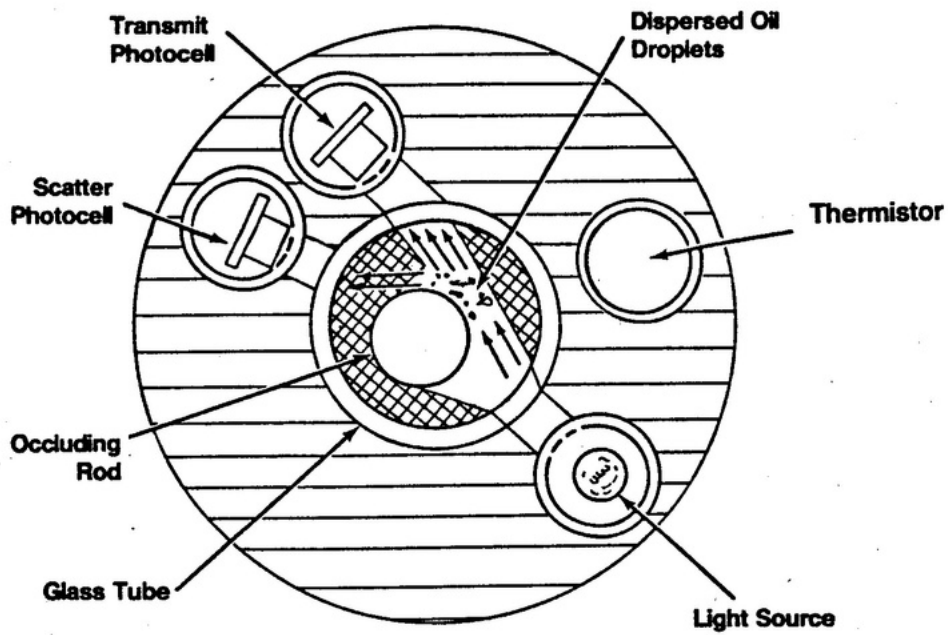

Cross Section of Sensing Head

LIÊN HỆ : 0979 349 375 CÔNG TY
LÂM TUỆ ĐỨC

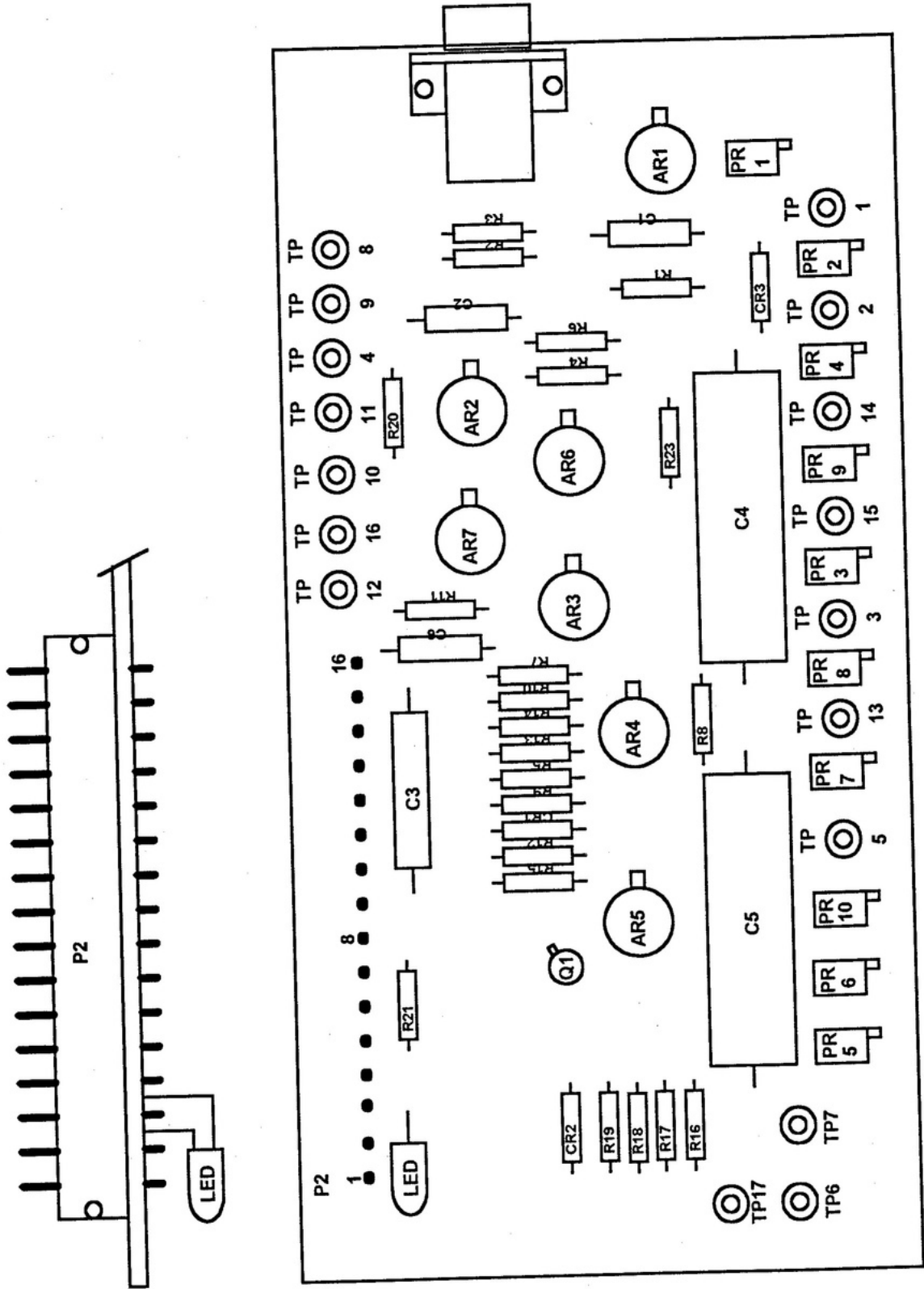
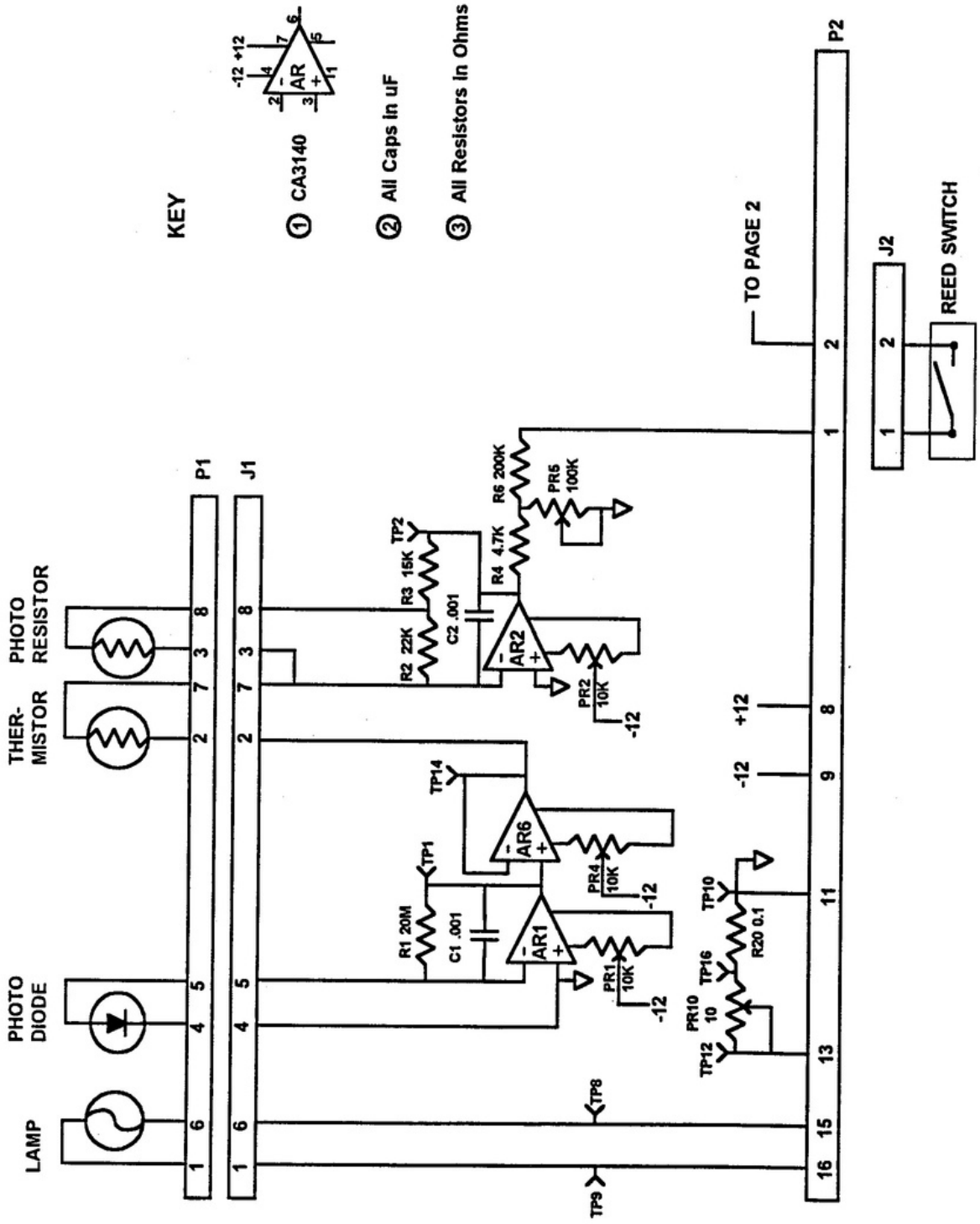
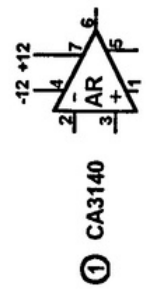

Figure 5 BA-200 Sensor Board
26



KEY



- ① CA3140
- ② All Caps in uF
- ③ All Resistors in Ohms

TO PAGE 2

**LIÊN HỆ : 0979 349 375 CÔNG TY
LÂM TUỆ ĐỨC**

Figure 6 BA-200 Sensor Board Schematic

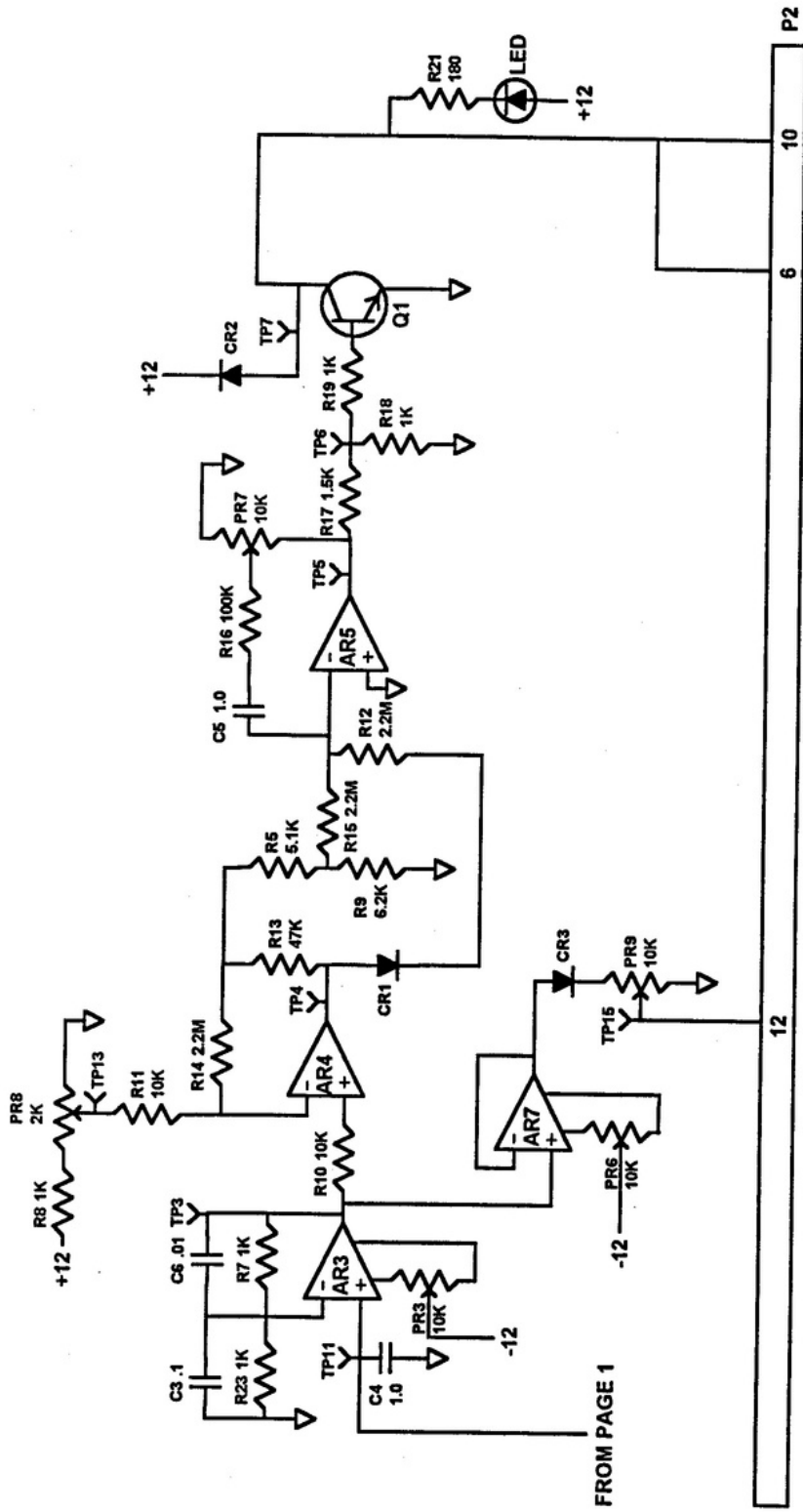

Figure 6(cont) BA-200 Sensor Board Schematic

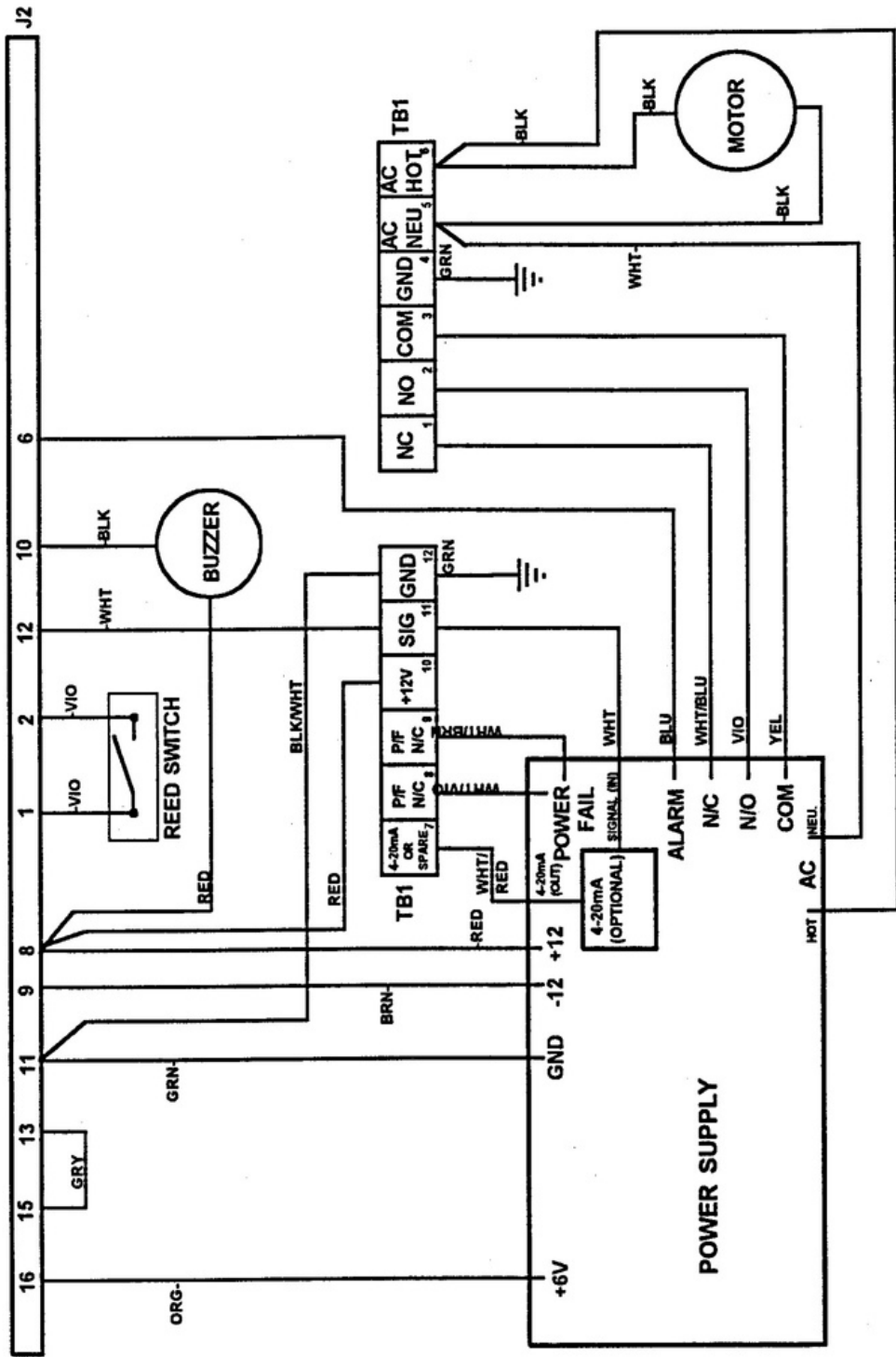

Figure 7 BA200 Power Wiring
29

LIÊN HỆ : 0979 349 375 CÔNG TY
LÂM TUỆ ĐỨC

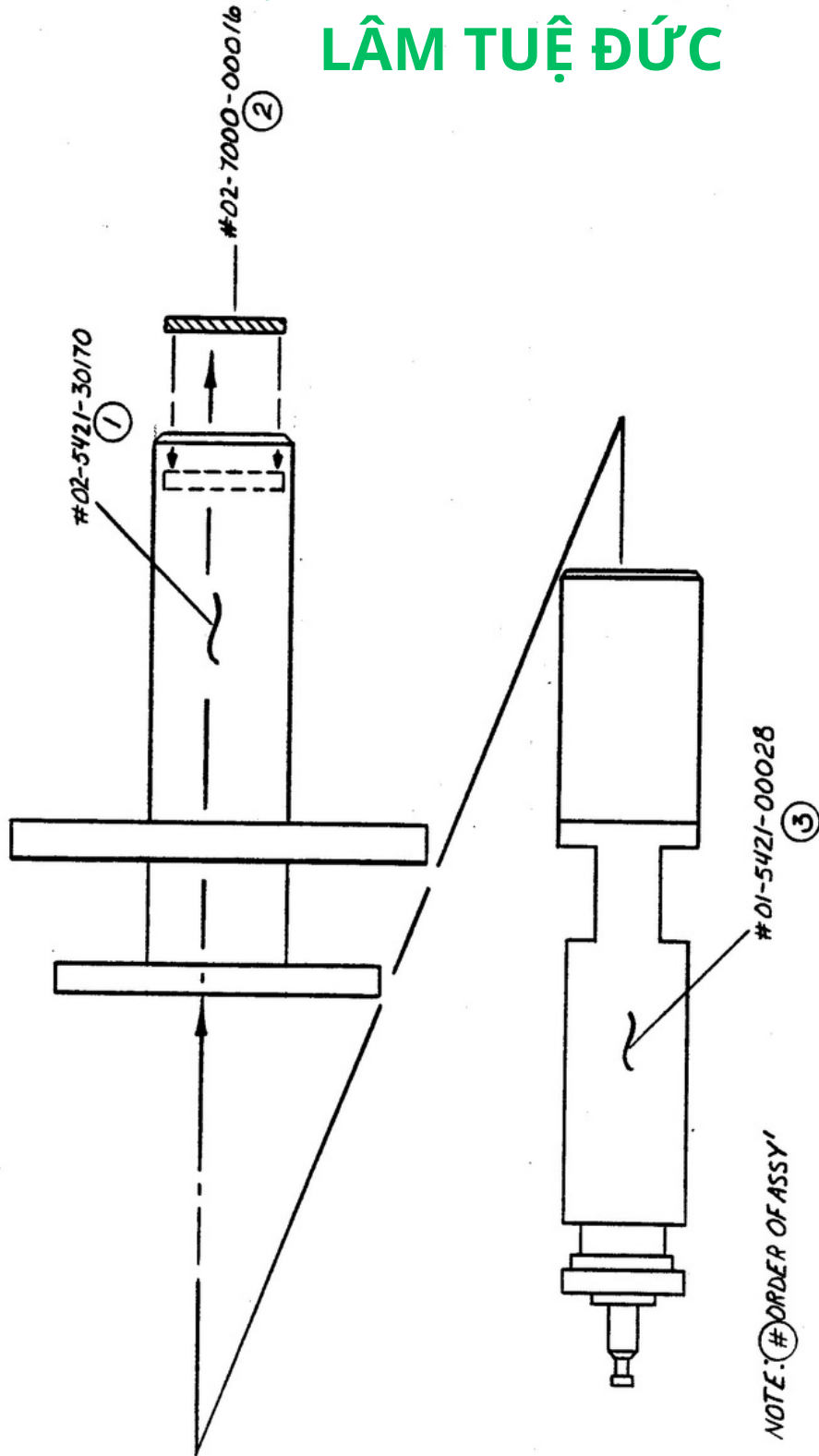

Figure 8 BA-200 Sensor Head IPB

LIÊN HỆ : 0979 349 375 CÔNG TY LÂM TUỆ ĐỨC

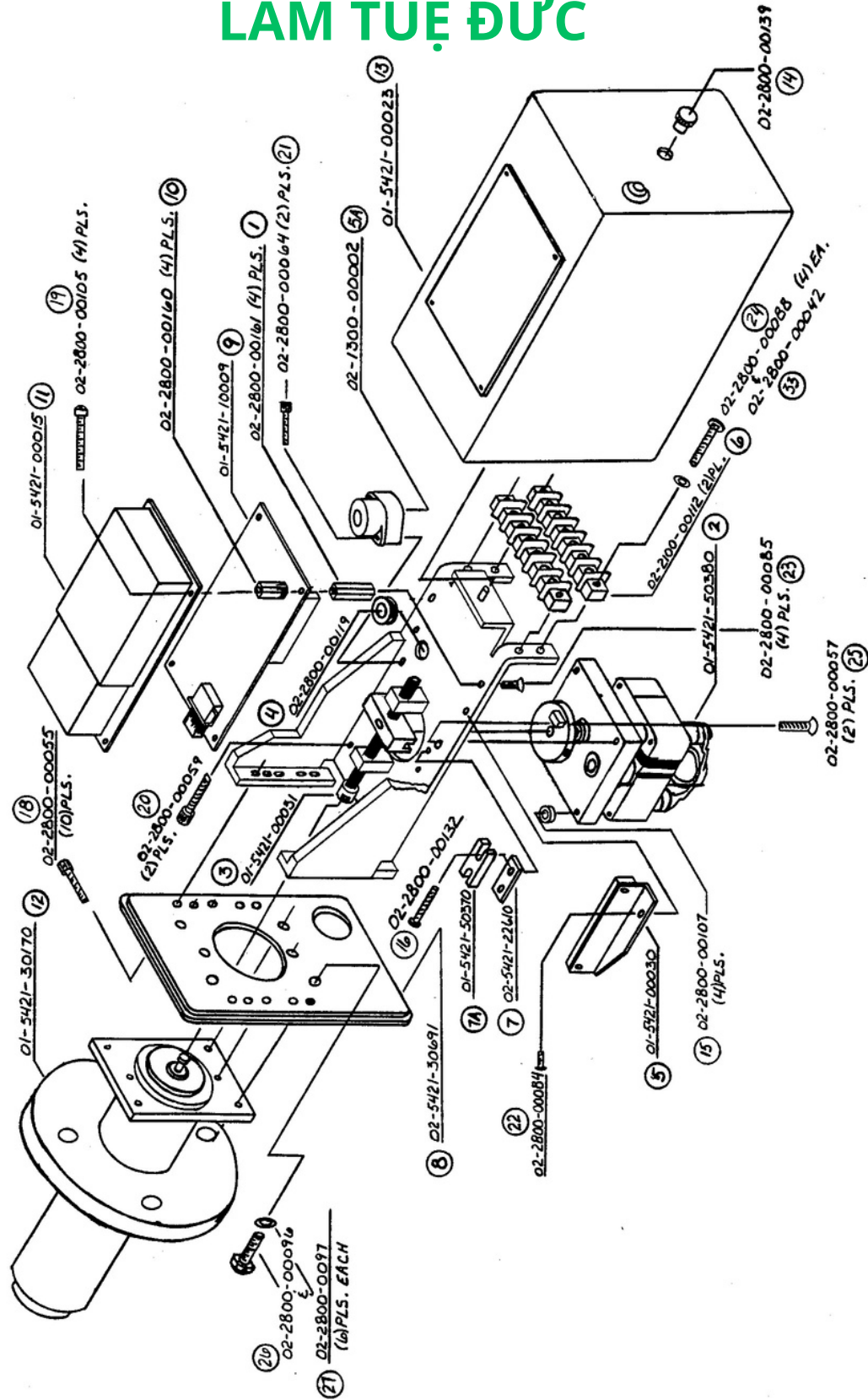

Figure 9 BA-200 Frame IPB
31

LIÊN HỆ : 0979 349 375 CÔNG TY LÂM TUỆ ĐỨC

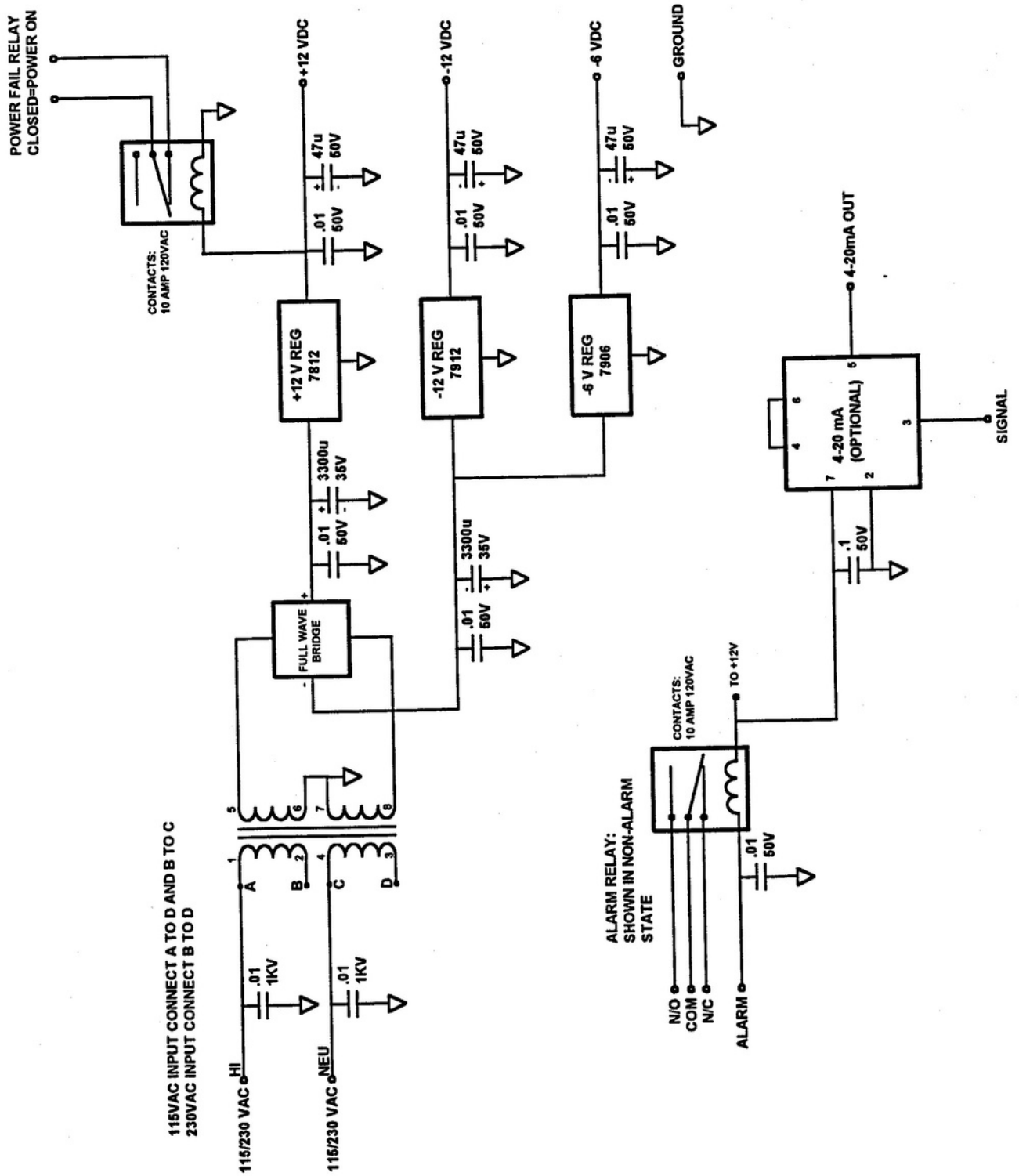
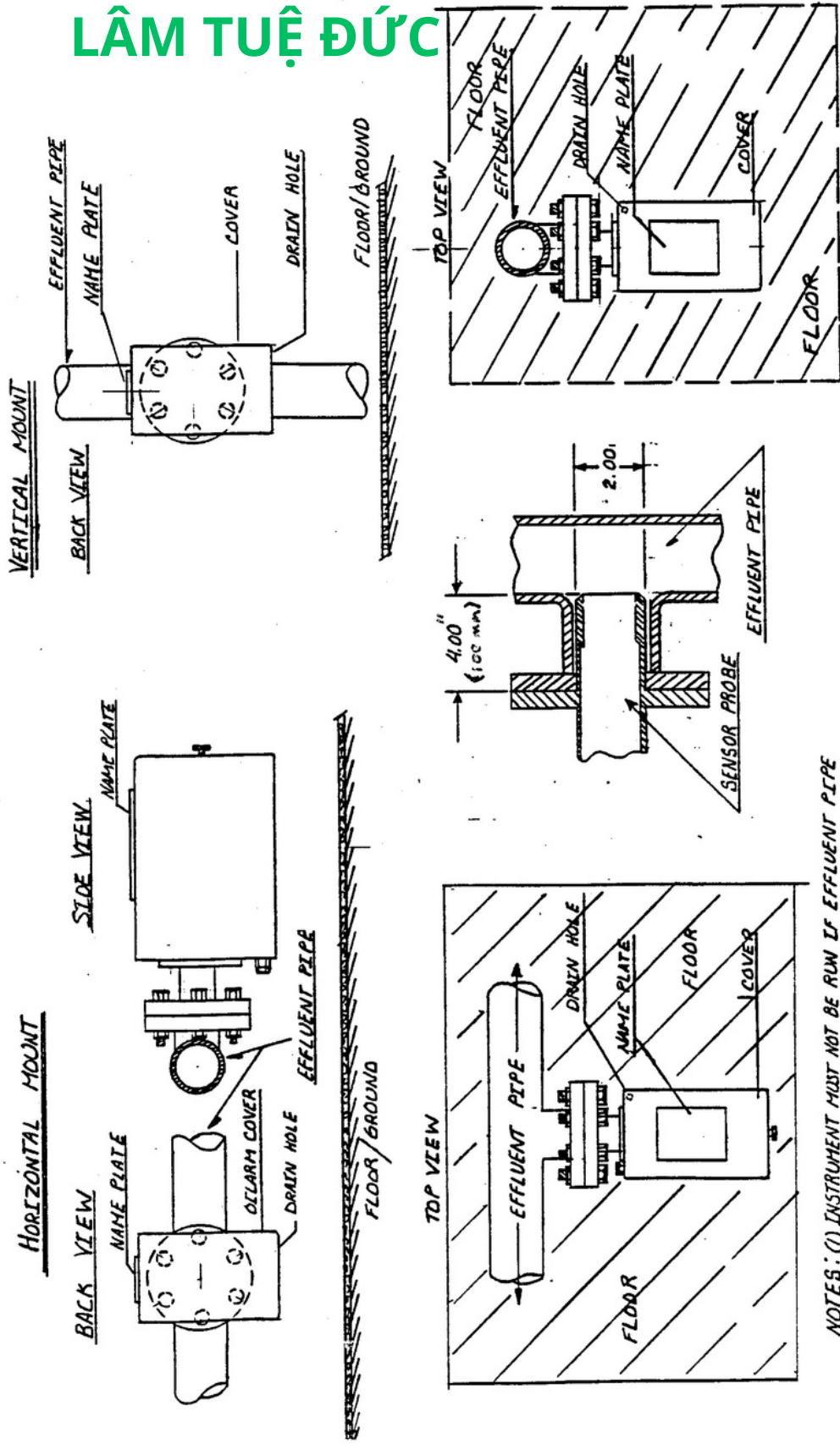

Figure 10 BA-200 Power Power Supply Card
32

LÂM TUỆ ĐỨC



- NOTES: (1) INSTRUMENT MUST NOT BE RUN IF EFFLUENT PIPE IS NOT FULL OF LIQUID.
 (2) NEVER COVER OR PLUG DRAIN HOLE ON COVER.
 (3) MAINTAIN MOUNTING ORIENTATION, AS SHOWN ABOVE WITH DRAIN HOLE AT LOWEST POINT.

Figure 11 BA-200 Installation
33

Appendix A

CL001 4-20mA CALIBRATION PROCEDURE

The following Calibration Procedure is to be used for the optional CL001 4-20mA current loop that may be installed on any model of the BA-200 OILARM. Note, the BA-200 and CL001 have been calibrated at the factory to your specifications. There is no need to re-calibrate the unit during pre or post installation. Attempts to re-calibrate the unit may lead to voiding of the warranty.

TEST EQUIPMENT:

4 1/2 DIGIT Volt Ohm Milli-Amp Meter (VOM)

TEST SETUP:

1. Set the BA-200 upright and place the black calibration sleeve over the top of the probe body.
2. Fill calibration sleeve with distilled water
3. Cover calibration sleeve with cover.
4. Allow unit to run for 5 minutes.
5. Place VOM ground lead on Test Point 10 (TP10) or anywhere on the frame.
6. Set VOM to Volts DC, 20 VDC Full Scale.
7. Replace water with fresh distilled water.

TEST PROCEDURE:

- 1 Locate the 4-20mA module on the Power Supply Card and refer to component layout below.
- 2 Center pots R7 and R4 (10 turn pots)
- 3 Move the jumper from JP2 to JP1
- 4 Measure and record the voltage on the JP1 pins (~2.0 volts DC)
- 5 **STOP!** Remove positive lead from BA-200
- 6 Set the meter up to read 200 MilliAmps full scale
- 7 Put the positive VOM lead to terminal seven (7) on the back of the BA-200 (Figure 3)
- 8 Adjust R7 to read in mA 10 times the Voltage recorded in step 4
e.g., if you recorded 1.987 in step 4 then you are adjusting for 19.87 mA (+/- 0.05)
- 9 Move jumper from JP1 to JP3
- 10 Adjust R4 to read 4.0mA (+/- 0.05) on the meter
- 11 Move jumper from JP3 to JP1
- 12 Repeat steps 7 to 10 until no adjustment are needed to maintain the recorded voltage (~20 mA) and 4.0mA.
- 13 Move jumper to JP2
- 14 Test complete.

Note: This same procedure can be used when connected to a current loop receiver. Simply ignore all references to the meter and take the readings from the output of the receiver.

LIÊN HỆ : 0979 349 375 CÔNG TY LÂM TUỆ ĐỨC

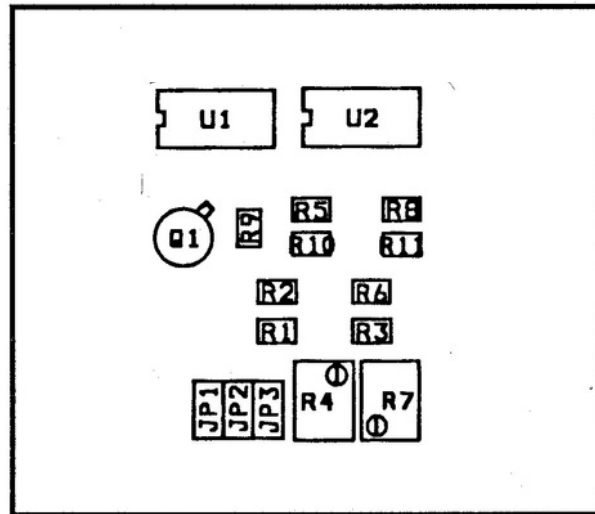

CL001 4-20mA Module Layout

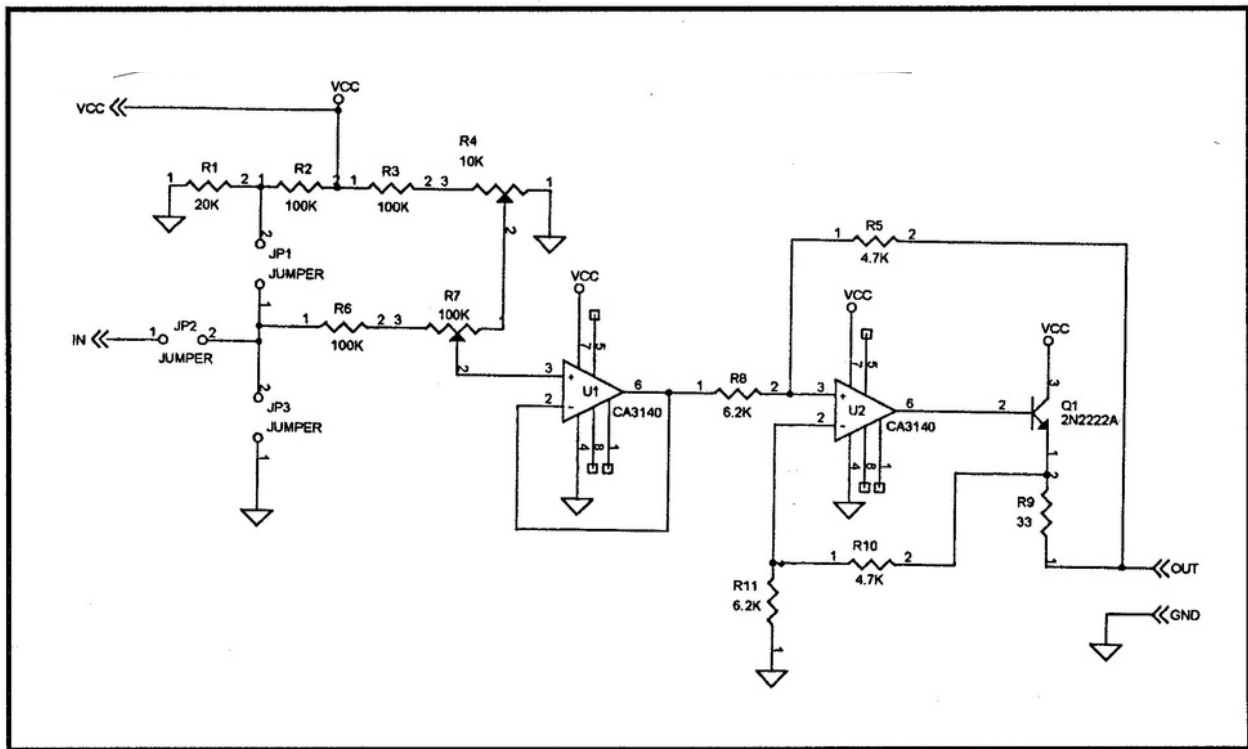

CL001 4-20mA Schematic